

Preface

Thanks for being our respected user of Futengda Electric Scooter&E-bikes,we hope you will enjoy your riding.

This manual is as a documentation guidance for all users to start correct operation and safer driving.We hope you will devote time reading it to know clearly before riding, we concentrate on all safe for all user.

Futengda Electric Scooter&E-bikes a pioneer in electric vehicle research and production in USA,our products are easy to operate, multiple function and tech-leading.You will love our products.

This manual will introduce the specification and guide you the operation, maintenance, safety precautions and after sales service.It will help you to enjoy your riding.

We typically remind you that,in the sake of your safe,please use our dedicated parts,and feel free to contact us if you have any questions or problems. We will do our best to meet your requirement.

Your satisfaction is our goal,we appreciate any your feedback and our products will thus improve continuously.

Tips: (warm tips)

Please check up all the parts if they are in good condition before riding contact with the distributor if you have find any problems.

Please comply with transport rules,and slow down in bad weather,and don't take person,in case suddenly braking.

You can drive in the rain or snow. Never drive in seeper which is deeper than 150mm,deeper than the bottom surface of hub, in case damaging the electric device.

The electric supply inside the vehicle is 36v or 48v battery, any of the contact point can not be touched with a wet hand, never touch them with metal material at the same time, or it will cause a big safe problem, please attention.

Please check up the braking ability regularly.

Don't refitting or disassemble any parts of the vehicle, if it needs a change, please change in after-sales service.

For the sake of others' safe, please don't lend it to someone who doesn't know how to ride it.

This product carry out the standard of Regulation (EU) No 168/2013.

Well study the features and operate before riding.

Manual of Futengda Electric Scooter&E-bikes

1. Assembly chart _____
2. General data _____
3. Wire chart _____
4. Assemble and Adjustment of all parts _____
5. Operation guidance _____
6. Maintenance _____
7. Endurance _____
8. Trouble shooting _____
9. After-sales service express _____
10. Warranty card _____

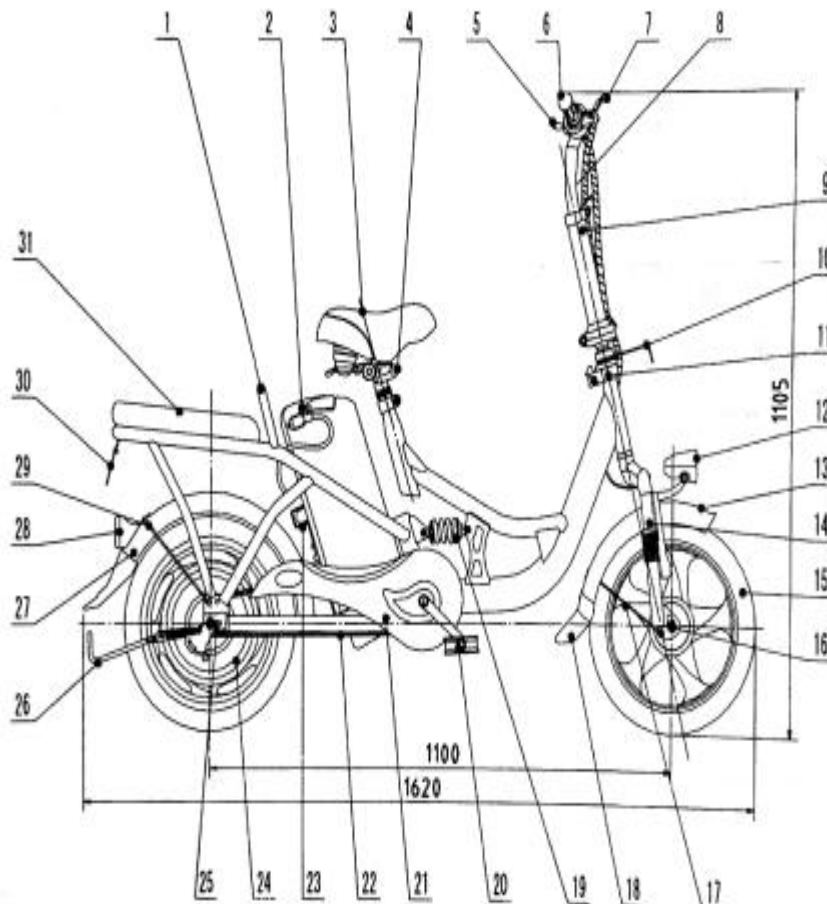

1	Frame Welding Assembly
2	Battery Components
3	Main Saddle Assembly
4	Flip Tube Assembly
5	Key
6	Hall Handle Speed
7	Brake Handle
8	Horizontal Tube
9	The Riser Tube Components
10	Basket of Fork
11	Handlebar Lock
12	Headlight Components
13	Front Fender
14	Fork
15	Front Tire Components
16	Front Alex Components
17	Front Fender Support
18	Front Tire Mud Board
19	Schock Absorber
20	Alex.chain.Pedal Components
21	Chain Cover
22	Chain
23	Battery Lock
24	Motor Components
25	Flywheel Assembly
26	Side Support
27	Rear Fender
28	Rear Reflector
29	Rear Fender Support
30	Rear Board
31	Small Saddle

Electric Bike Basic Description:

Size(mm)		1620*575*1105	Motor	Motor	DC Blushless
Front & Rear Wheelbase(mm)		1100		Voltage(V)	DC 48V
Gross Weight(kg)		≤35		Power(W)	250
Max Loading(kg)		120(including driver)		Rate Speed (r/min)	290
Max Speed(km/h)		25		Torque(Nm)	>6.8
Ranging Per Full Charge(km)		40km	Controller	Voltage(V)	31±0.5
Battery	Battery	Lead acid battery		Current	16±1
	Capacity(ah)	12	Charger	Charge Form	Three Phrase
	Voltage(V)	48V		Input Voltage	50Hz 220V±10%

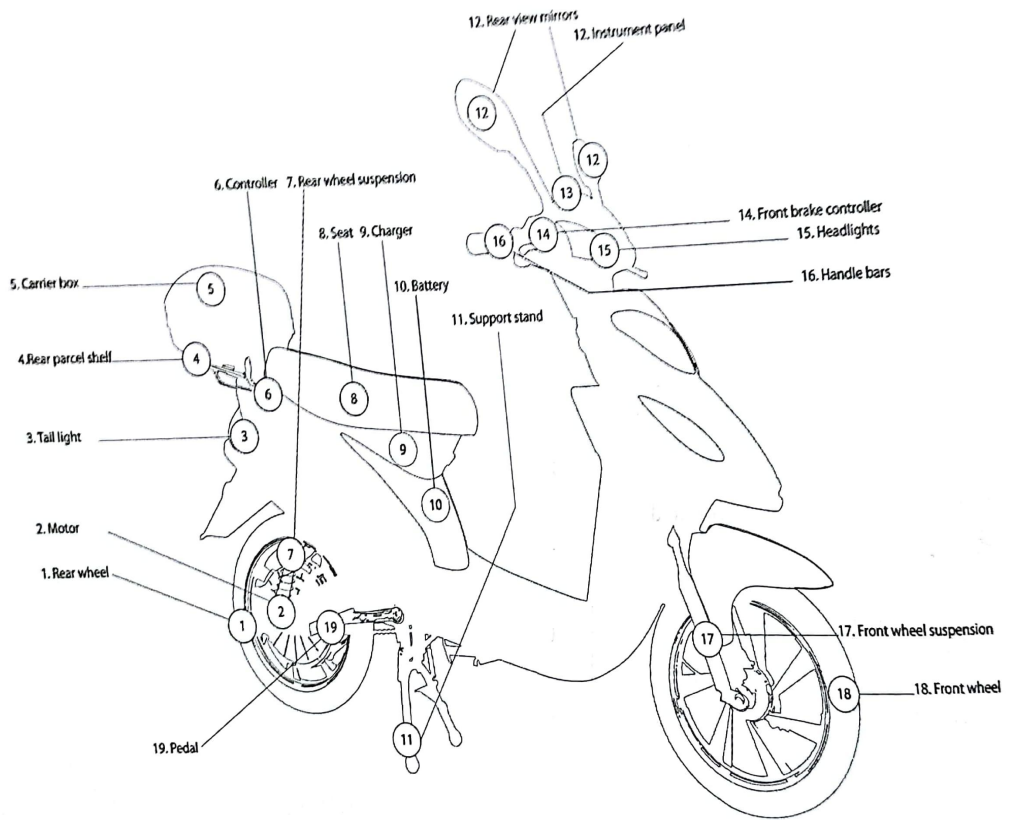

3

Size (mm)	1500*900*400	Motor	Motor type	Brushless
Wheelbase(mm)	1130		Rated voltage (V)	DC 48
Net weight(kg)	72		Power(W)	250
Loading(kg)	150		Rated speed(r/min)	450
Max speed(km/h)	25		Rated torque(Nm)	>6.8
Endurance(km)	55	Controller	Under voltage protection value(V)	42+_0.5
Battery type	Lead-acid battery		Over-current protection value(A)	23±1
Battery Capacity(Ah)	12	Charger	Charging form	Three period
Battery Voltage(V)	48		Input voltage	50Hz 220V+_10%

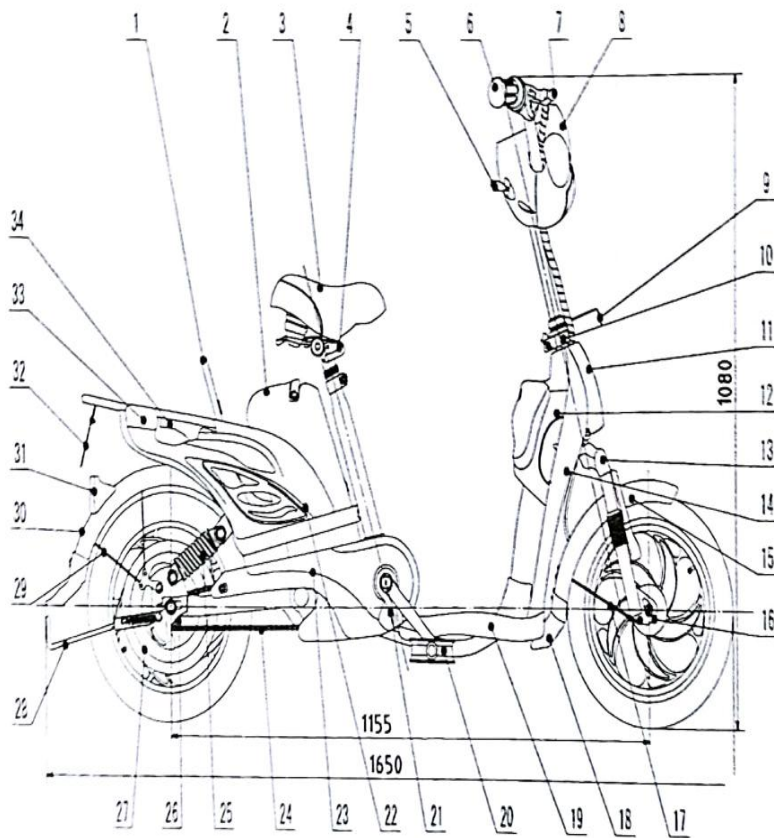

1	Frame Welding Assembly
2	Battery Components
3	Main Saddle Assembly
4	Flip Tube Assembly
5	Key
6	Hall Handle Speed
7	Brake Handle
8	The Riser Tube Components
9	Brake of Fork
10	Handlebar Lock
11	Panel
12	Box Components
13	Fork
14	Weather Board
15	Front Fender
16	Front Tire Components
17	Front Alex Components
18	Front Fender Support
19	Foot Board
20	Alex.chain.Pedal Components
21	Chain Support
22	Battery Lock
23	Guard Components
24	Chain
25	Schock Absorber
26	Flvwheel Assembly
27	Motor Components
28	Side Board
29	Rear Fender Support
30	Rear Fender
31	Rear Reflector
32	Rear Board
33	Skirt Net
34	Controller Box

Electric Bike Basic Description:

Size(mm)		1650*645*1080	Motor	Motor	DC Blushless
Front & Rear Wheelbase(mm)		1155		Voltage(V)	DC48V
Gross Weight		≤55		Power(W)	250
Max Loading(kg)		150 (including driver)		Rate Speed (r/min)	450
Max Speed (km/h)		25km/h		Torque(Nm)	>6.8
Ranging Per Full Charge(km)		55km	Controller	Voltage (V)	42 ± 0.5
Battery	Battery	Lead acid battery		Current(A)	17 ± 1
	Capacity (Ah)	12	Charger	Charge Form	Three Phrase
	Voltage (V)	48		Input Voltage	50Hz 220V ± 10%

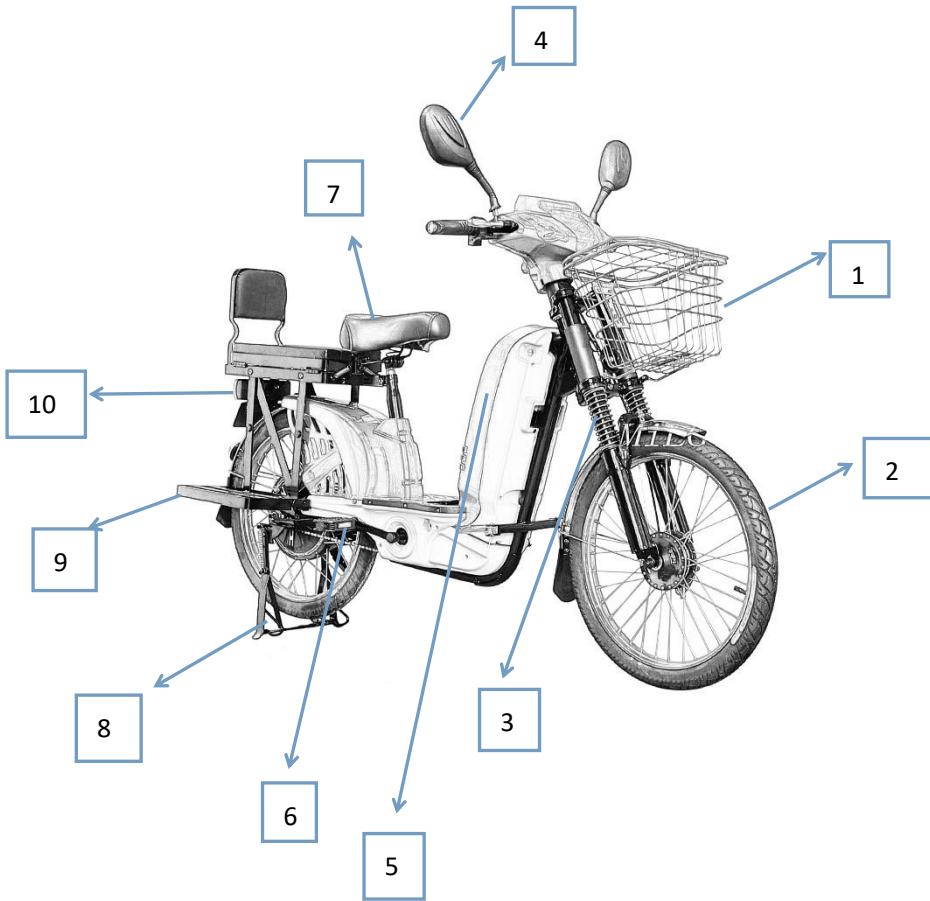

1	Front basket
2	Front wheel
3	Front fork
4	Rear view mirrors
5	Battery box
6	Pedal
7	Seat
8	Double brace
9	Side double flip
10	Rear tail light

Electric Bike Basic Description:

Size (mm)		1780*650*1080	Motor	Motor	DC Blushless
Front & Rear Wheelbase(mm)		1185		Voltage (V)	DC48V
Gross Weight(kg)		≤68		Power (W)	250
Max Loading (kg)		150		Rate Speed	360
Max Speed (km/h)		25		Torque (Nm)	>6.8
Ranging Per Full Charge (km)		55	Controlle r	Voltage (V)	42 ± 0.5
Battery	Battery	Lead acid battery		Current (A)	17 ± 1
	Capacity	12	Charger	Charge Form	Three Phrase
	Voltage	48		Input Voltage	50Hz 220V ± 10%



1	Rear wheel
2	Motor
3	Front wheel
4	Controller
5	Rear wheel suspension
6	Seat
7	charger
8	Battery
9	Support stand
10	Rear view mirror
11	instrument panel
12	Front brake controller
13	Headlights
14	Handle bars
15	Front wheel suspension

Size (mm)	1530*920*450	Motor	Motor type	Brushless
Wheelbase(mm)	1130		Rated voltage (V)	DC 48
Net weight(kg)	75		Power(W)	250
Loading(kg)	150		Rated speed(r/min)	45
Max speed(km/h)	25		Rated torque(Nm)	>6.8
Endurance(km)	40	Controller	Under voltage protection value(V)	42+_0.5
Battery type	Lead acid battery		Over-current protection value(A)	17±1
Battery Capacity(Ah)	12	Charger	Charging form	Three period
Battery Voltage(V)	48		Input voltage	50Hz 220V+_10%

Assembly and adjustment

Adjustment to the throttle

Handlebar should not be lower than the minimum limit of depth to ensure safety.

Tightening the handle stem after it is righted direction. Lock the bolts in the center of thrills with a suggested moment not less than 18n.m(see picture2).

Clamp the front wheel with legs against handlebar,grip the thrills and adjust the handlebar to 90° towards the frame,tightening the screw next.(see picture 3).

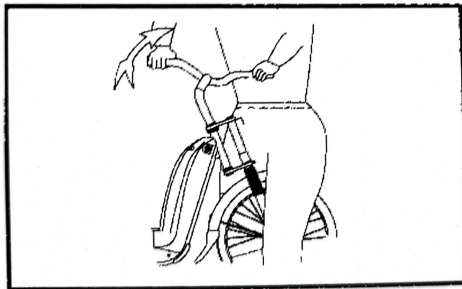

Picture 2

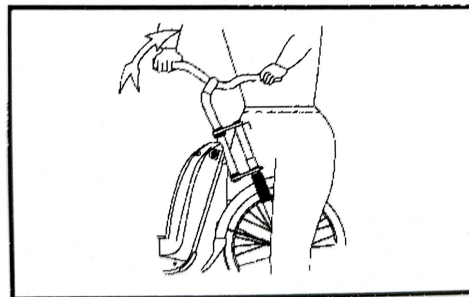

picture 3

Adjustment to the front wheel

The front wheel should be assembled in the front fork, make the gap same between the right and left the same,

tightening the the front axle nut ,and the suggested moment not less than 30 N.m between front and rear wheel nut.(see picture4)

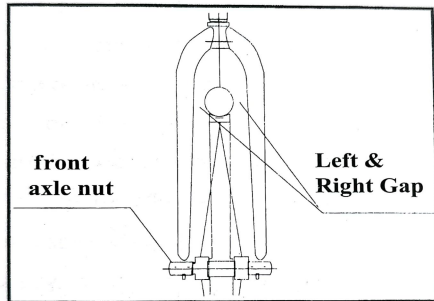

Picture 4

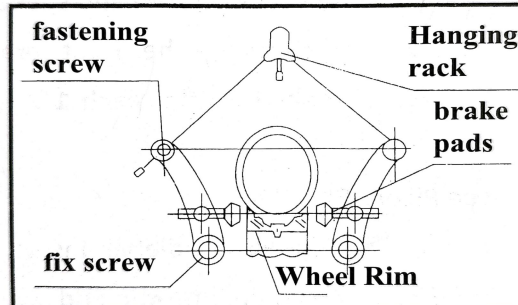

picture 5

Adjustment to the front brake cover axle,

Adjustment to front brake:

The best distance from front brake cover to alloy rim is 2mm;

It is the best adjustment the position of suspension wire frame is 90° towards the suspension wire.

Please change a new inner brake shoe when it was worn down 50%,as it will decrease the braking function.

Adjustment of front/rear drum brake

Adjustment of front drum brake: when you loosen front drum ,adjust the moment between nut and brake when the brake is flexible,and there is no jam, then the front wheel runs is the best situation of Drum

brake.(the rear wheel is the same) (see Picture 6)

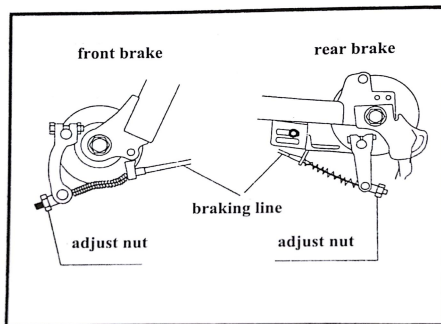

Picture 6

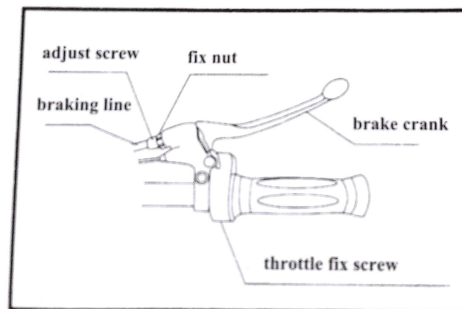

picture 7

When the abrasion of brake shoes surpass $\frac{1}{2}$,it might influence the brake performance,you should replace it in time.

Adjustment of Brake throttle and speed handlebar

As(Picture 7) checking the right brake bar,when the distance of brake throttle reach $\frac{1}{2} L$,it can be braking absolutely.(see Picture 6)

Making the speed handlebar insert for 115-120mm,fastening throttle and screw,the throttle will be flexible after installation.

Adjustment of rear brake

Adjustment of rear brake:Loosen the fastening nut of adjusting screw.Adjust the angle of rocker till the braking shoe just touch in no friction condition,lock the nut tightly.(Picture 8)

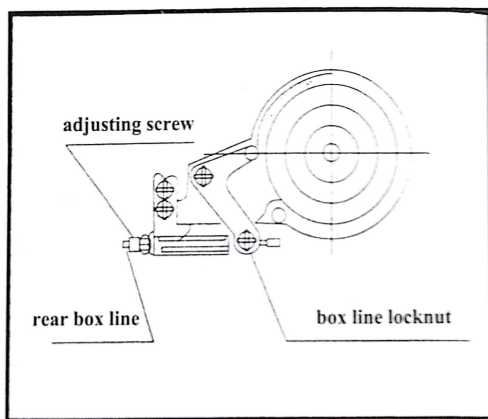

Picture 8

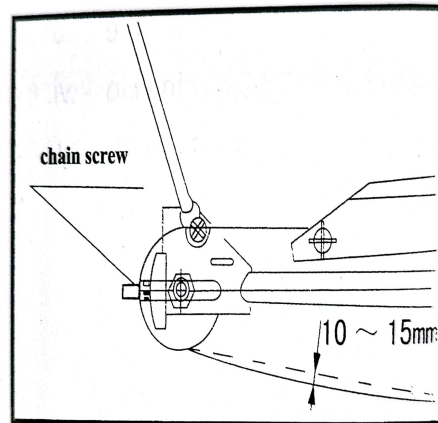

Picture 9

When the abrasion of brake flap achieve the degree of 1/2,once it influence the brake performance,you should replace the brake flap in time.(inside of the brake forbid pouring into oil)

Chain adjustment

Chain adjustment:Adjusting rear wheel screw till the chain is in the suitable degree of tightness and spin neatly.The best situation is that chain side droop for 10-15mm. (Picture 9)

Saddle adjustment

When people sit in the saddle and just touch the ground should be the most suitable height.(see Picture 10)

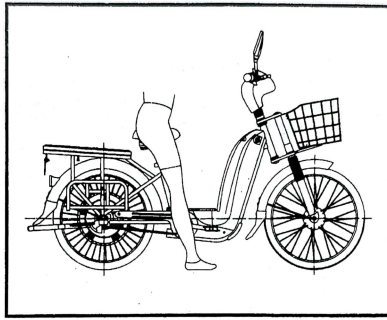

Picture 10

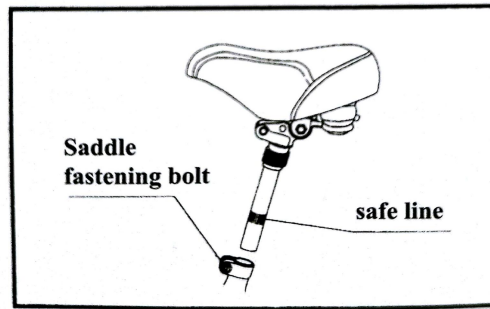

picture 11

Saddle should be inserted into the tube not less than remarked safe area. Tightly screw the bolt between saddle and tube to a moment 18N.m (see Picture 11)

The model which choose suspension saddle should adjust to 75kg according to the standard while leave factory. Adjustment range of this shock absorb's spring (50-100)kg can be adjusted in accordance with self-indulgence. operations as follows: pull out the saddle tube, adjust the bottom of shock absorb's bolt, Turning clockwise means increasing the spring force to 100kg, on the contrary, the spring force decreased to 50kg.

Folding handle bar adjustment

1: Please lock all parts of the quick-release device before riding

2: When riding in a handlebar stem should be no displacement axial warp

3:After folding the legislation itself should be no loose combination (see picture 12)

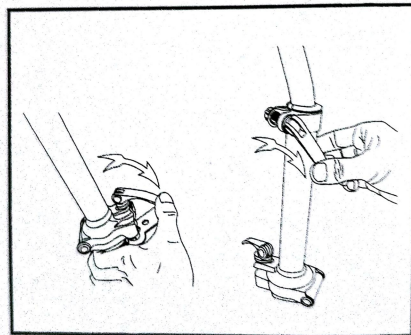

picture 12

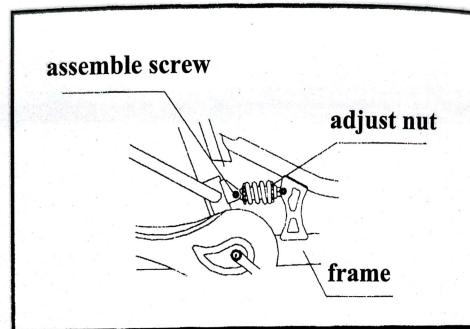

picture 13

After the suspension shock adjustment

Electric bicycle production according to the standard adjustment in 75KG, graphical models of shock absorb spring adjustment range of 50-100KG, the user can according to their own weight and I used to comfort the re adjustment, the specific operation as follows: clockwise rotation adjusting nut to increase the force of the spring to 100KG, counter clockwise to decrease to 50KG (see picture 13)

Routine maintenance and repair

Technical parameters of charger

electric bicycle charger adopts configuration three stage charging method: constant current and constant voltage and floating charge, charging into the initial state of constant current charger, charging indicator light, when the power is close to full, charging indicator light turn green and into the state of floating charge

Data Voltage	Input Voltage	Rated power	Charge Voltage	Charge current	Charge hour
36V	AC 220 V+_10/100	80W	44.3	1.8	6-10h
48v	AC 220 V+_10/100	140W	59.0	2.5	6-10h
60V	AC 220 V+_10/100	160W	73.5	2.5	6-10
72V	AC 220 V+_10/100	180W	88.4	2.5	6-10

Attention:

In the power system voltage instability in the region, when the grid voltage fluctuation than AC220V+_20/100, please recommend the use of small power AC voltage stabilizer, otherwise easily lead to the charger to charge the battery charger failure or lack of

The charger is not connected to the ground

Charge method

Charging battery with electric bike

The first electric vehicle parked in a power supply socket place, then reached special charger inserted in the battery box charging excuses, and then plug connected with an AC power supply

When the charger is charging indicating lamp as the light turned green, said battery has reached more than 90/100, the battery has been available, proposes to charge 1-2 hours, let the battery charging saturated.

Remove the power plug, and then unplug the battery end plug, the end of charge

Charging battery and electric vehicle separately

Electric vehicle battery box from take off, to have a 220V AC power

supply place, first will charge the plug connected with the charging port, and then the power plug and a power socket connection (see picture 14)

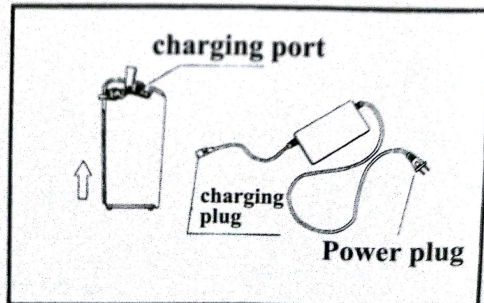

Picture 14

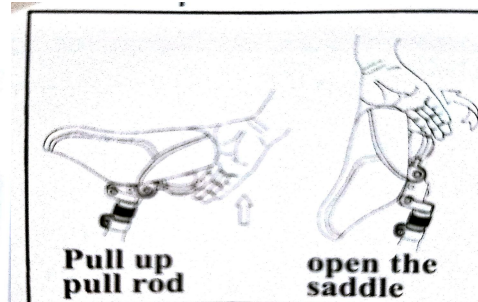

picture 15

Remove the battery steps

People standing on the left side of the vehicle, open the battery lock
he right hand pull back pull rod and lift saddle, saddle forward flip
Hold the battery box handle up, remove the battery box
Saddle down when need 3-7KGF about pressure, flip the saddle lock in
place in order to guarantee ride (see picture 15)

Pay attention:

When necessary, the battery box with right hand , left hand supporting

This method is only suitable for turnover saddle models

Please do not deposit the battery and to the battery

discharge in the following situation

- 1.High temperature, high humidity, moisture, or temperature and humidity has changed so much for the occasion.
- 2.The sand and dusty so much in the area
- 3.The stove and open fire the place
- 4.Close to the heater and humidifier place

5. Easy to the water and other liquid pour to the place
6. Placed on flammable items charge
7. Battery charging, the charger may not be covered with items, so as to avoid accidents

Other attention about charging and charger

1. The battery box exposes in outside receives an electric shock the spot is charged, forbid strict the child with hand touching, creates the short circuit to be able to cause the electric shock wound, Forbid strictly the electric conduction object simultaneously contacting the two-pole electronic contact, the big electric current short circuit produces the electric arc to be able to create the security accident.

2. Battery charger and is being charged should be in a safe place out of the reach of children .

3. When battery charger use and depositing should prevent the liquid and in the sweepings permeating battery charger, prevents internal short circuit damage electricity component

4. Do not place the battery in a closed bedroom, charging, keep batteries charged for ventilation and the charging process, if it is discovered that charger Temperature rises too high or continuous charge after 10 hours is still not go green, please immediately stop charging the battery and contact our after-sales contact

5. Please do not use other brands the battery charger for this company product battery charge, other types and other factory battery not suitably uses this battery charger to charge. Otherwise will not provide the return ,exchange ,repair after service for charger and battery.

Important note:

😊 If some problem happen on charger or battery, the charge indicator can't change the color in a long hours (general smaller than 10 hours), and the charge indicator will be in red all the time. At the same time, the battery is hotter than before, please stop to charge, and contact us immediately .

😊 Please charge it, after use. And Run out of the battery every 3-4 weeks in one time,then charge 12 hours. This is a good way to activate active material in the battery plate and make the battery life longer.

Battery Technical parameters

Unit battery size	Unit weight	Battery capacity	Connect way
151*99*98mm	4.3kg	12V/12Ah	Series connection
151*99*94mm	4.1kg	12V/10Ah	Series connection

Regular maintenance for parts and the checking information:
In order to make your electric vehicles in the best condition,please keep in regular maintenance,please check and clean the following:

😊 If the The air pressure is OK in the front and the rear tire

😊 If the frame,the parts are clean enough

😊 If the pattern of the outer tires are Badly worn

😊 If the Front and rear wheel axis are with oil lubrication, and work smoothly

😊 If all the connector are tight,and not broken

😊 If the reflector are OK

😊 Driving for some time, and check if the Front and rear wheel spoke tension is normal, if not, please contact us.

😊 Motor, battery, controller, charge maintenance-free components, please do not take them away by yourself, any problem can contact us.

Maintenance instructions

😊 Avoid high-pressure water wash, so as not to cause the fault of electronic components and wiring soaked

😊 Non-corrosive solvent cleaning, so as to avoid the plastic parts and paint surface discoloration, corrosion, deformation

😊 When clean the outside shell, please use the Neutral solution

😊 Front and rear axis, central axis, pedal, chain, fly wheel, braking cables need to Oil injection every 1-2 month, and the braking cables, chain use the L-AN64GB443 Lubricating oil, the rotating parts (Front wheel axle Bowl, front fork parts, Middle axle Bowl) use Lithium base grease NO.3 .

The flowing parts are forbidden to clean with oil, the tires, vehicles body, front and rear brake.

Driving operation

1. know the main operate parts

Main Power switch

★ 1. General power switch is for electric main lock, is a high current switch, located in the main road between battery and controller. The general power switch is opened, is in position "ON", then the monitor

light up.

- ★ 2. When the vehicle is in an abnormal situation, must be timely close the switch lock general power switch

Speed changing part

1. The speed change throttler is on the right side of the vehicle, turn it into inner will speed up, loose will slow down.

2. Please pay attention to cultivate a "light rotation to" habits, excessive force or rotating in the opposite direction may lead to speed the mechanical artificial damage, thus affecting the performance of speed regulation.

Brakes and power braking device

1. The power left-hand and right-hand side there is a front and rear brakes, and use the method with a bicycle, the different point is an integral to a micro-power off switch, when a manual brake is automatically given a signal from the controller power off, the motor stops working.

2. If the power switch is not return, may not be able to start the vehicle, for example, some users hung bag on the brake handle, so the micro switch work, the electric vehicle can not start, this kind of situation should be promptly eliminate by yourself

Turn signals and Horn

3. Headlight Switch is set up on the left side of the handlebar, please turn on the headlights when driving during the night, which is conducive to safety. Turn signal switch is set up on the left side of the handlebar, when want to turn left, just dial to the left, when want to turn right, just dial to the right side. Horn switch located on the left handlebar, press the button, horn working.

Support Automatic Lock

1. For some electric vehicles, not have single support power-off protection switch, when the electric vehicle parking, the single support dial to the standing position, even if the power lock is in an open state, when turning the speed bar, it will not work, so as to avoid operation accident when parking.

Power Display

1. When ready to ride, opened the lock by the key (Turn to ON Gear), the display panel power indicator light (BATTERY) and red power

indicator light (POWER) are bright, shows the power is on.

2. When riding, with the consumption of electricity and lights on the control panel go out one by one (by ordinary road uniform State). When all the LED are all off, and under voltage indicator light, driver should use the foot pedal, the battery needs to be charged before use.

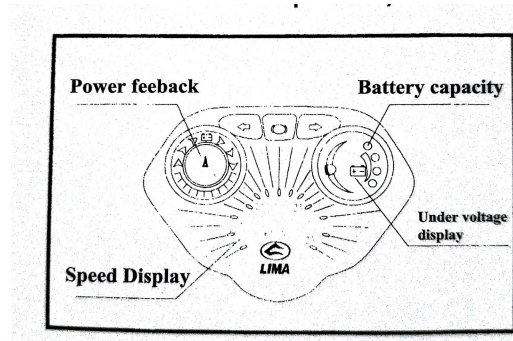

Picture 16

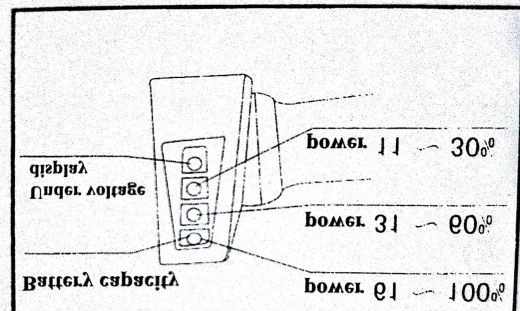

picture 17

Notes:

1. When riding, because of frequent turn-on, road condition, loading, maybe some power indicator lights keep on, but it still can't be propel. Low battery will result in low voltage indicator, that's the protection of low voltage system, this is normal.

2. When the battery powered off, the voltage indicator light will be on. Turn on the bike again, the voltage indicator will be up and the power indicator lights on. The meter show the power is ok, doesn't use this kind of power, otherwise the batter will be damaged.

Suggestions:

1. After you riding a long way, please use pedals more to save power to ride a long way.
2. Once turn on the bike, use pedals assisted let the speed more than 5km/h, then use throttle to propel.
3. When riding, you can also use pedals to propel.
4. When the bike on downhill road, do not use throttle, keep the bike go freely.

Basic operation procedure:

When using double stand, turn on the bike to check condition of motor, meter, power-off brake system, braking performance. If not normal, send the bike to our after-sales service place. If normal, put off the double stand, sit on the saddle, rotate the throttle inward to be normal speed, so the bike go through the process from starting to the max speed. When slow down, release the throttle or put it in the middle place. Other driving technology is the same with the bicycle.

Safety driving precautions:

1. After reading the instruction manual and learning the electric bike knowledge, then use the bike, and don't let one that's can't ride to use the bike.
2. When turning around, please slow down, and avoid sharp

turning.

3. Electric bike belongs to non-motorized vehicle, please riding on the non-motorized lane. Be careful with the color lights and obey the traffic rules.
4. Do not loading another person.
5. Keep the brake system in a good condition, please slow down and brake in advance when raining and snowing to avoid traffic accident.
6. Estimate the power by power indicator, more lights, more power.
7. Open the lights when riding in the evening.
8. When riding on rugged road, slow down to avoid damage to wheel and tire.
9. Do not borrow you bike to the minor, the pregnant and the disabled to avoid damage to the person and the bike.

Daily use precaution:

1. Check the tire pressure and brake condition before riding.
2. Check if the non-moving parts rub with the moving parts.
3. Check the condition of battery lock, if it will loose when riding. If in loose condition, deal with it immediately to avoid leak out of

electricity.

4. Check the electrode condition, if not clear and polluted, to deal with it immediately.

Riding precautions:

1. To avoid something sharp puncture the tire.
2. Use pedals to start, when riding a long way and climbing, also use pedal assisted to propel to save power and protect the circuit.
3. Pushing the bike when on the gravel road or the road uneven.
4. When parking and or pushing the bike, turn off the power.
5. Do not accelerate when down slope.
6. Do not add a lock on front fork.
7. Check the battery before riding.
8. If something wrong, pull over to check the condition.
9. Do not take off spare parts if you are not professional.
10. Use the spare parts from our company, we will provide after-sales service for our parts.

Placing bike precautions:

1. Place the bike smoothly to avoid turnover.
2. Do not put the bike in the sun in a long time, especially do not the bike with LED meter in the sun.
3. Check the fasteners condition, especially the screws on the wheels. If

the screw loose, fasten it immediately to avoid accident.

4. Check the brake condition, adjust immediately.
5. Check the tire, if the wheel run out, adjust the spokes of the wheel.

Important notes:

1. Do not rap, smash and burn the battery, otherwise the corrosive liquid will be out, resulting in damage to people and objects, even explosion.
2. Do not deal with the abandoned battery by yourself, send it to our company service center, and do not throw it away, it will be harmful to the environment.
3. When place the batter alone or charge alone, keep it stand up.
4. When replace the battery, replace a set. When welding, keep the vent of battery in the box up.
5. When against wind, climbing, starting, please use pedals, to extend life of the battery and motor. When in all-electric mode, if loading or climbing in a long time, it will reduce the motor output power automatically. It is protection function, not nonfunctional.

Power off at moment:

The mainly reason for power of at moment is bad connecting, or the switch of braking power off doesn't work.

Trouble shooting:

1. User can go to After-sales service for check up.
2. User can check himself on the basis of following rules:

3. check up if the contact shoe and contact column was polluted,if so clear it.
4. check up that whether the elastic of connection is working or not,if not working,change another socket.
5. Check up if the plug-in is loose or fall down,if so reconnect it.
- 6,check up if the switch of power off is in right place,if it got stuck by something,clear it,and then put the braking handlebar back to right place.
- 7.check up if the switch of braking power off was short circuit caused by rain,if so dry up the water of switch by a hot-air blower.
8. The vehicle should avoid being caught in the rain outside.
9. Trouble shooting for shoot-through problem:when the controller is shoot-through,and the it can't be cut off by braking,user should take following emergency measures:
 - 1.cut off the switch of main power lock;Cut off the main circuit power supply,force to brake the vehicle,burn out the fuse wire by over loading,cut off the main circuit power supply,and the motor will stop working.
 - 2.Rider should stay calm,and keep body balance,to make sure that the rider can take emergency measures effectively.User should take the vehicle to the after-sales service for repairing after the the switch of main power was cut off.

About Endurance

1. endurance per fully charge \geq 45km (normally)
2. general loading:75kg
3. power consuming per fully charge \leq 0.66kwh
4. Full kit weight: \leq 50kg
5. Speed: \leq 20km/h

Range Road Condition	Range			Driving condition
	25km	35km	50km	
Flat road				25°C standard loading
Flat road				25°C, windy standard loading
uphill				25°C standard loading

Footnote:standard state means speed is 18km/h,new battery,battery volume is 12Ah/48v,wind speed is 2-3 levels,normal temperature 25 °C , no start,no braking etc.Flat road condition,normal tire pressure,loading 75kg,the vehicle own weight below 50kg.The battery capacity will phase down as the using time adds.The battery capacity will phase down when the temperature fall down as low temperature will lead the charge can't be completely released.These two reasons both will affect the endurance a vehicle goes.

Tips:Reduce start and brake will improve a high travel route.And the battery capacity will drop 1% when the temperature fall down 1 degree regard 25 °C as benchmark.It is normal situation when the endurance fall down caused by low temperature.

No.	trouble	Possible reasons	solution
1	Speed handlebar not working or the highest speed is lower	<ol style="list-style-type: none"> 1. low battery voltage 2. speed handlebar disconnected 3. wire disconnected 4. handlebar is broken or the pedals turning 	<ol style="list-style-type: none"> 1. fully charge the battery 2. screw down the speed handlebar 3. repair in after-sales service. 4. Change another handlebar

		with wheel,lead to shoot-through.	
2	Power on but motor not working	5. Battery or disconnected 6. low battery voltage 7. braking in other section 8. timing cord disconnected 9. wire disconnected	1. reconnect it after repair 2. change with a new motor 3.air in after-sales service.
3	Endurance shorten when fully charge	1. lack of air pressure 2. improper charging 3. charge malfunction 4. battery out of usage life	1. fully gas-filled 2. fully charge and check up all the wire is connected good 3. change new batteries 4. use pedals
4	Charger not working	1.e connect wire loose with batteries. 2.charger socket drop or plug is drop with charger socket 3.the inside fuse of charger burned out	1.screw down the socket and plug-in 2.change new fuse 3.reconnected the wire
5	others	You can't shoot the troubles above or you don't know when is the trouble	1. repair in the after-sales service 2. Call us for suggestion 3. Never opening the parts yourself.

Regularly checking and maintenance

Check:✘Adjust/Replace:▲

Lubricate:●

Check list	Everyday	60days	180days
1.Air pressure,indent on outer tyre	✘	✘	✘▲
2.Brakes	✘	▲	▲
3.Horn	✘		
4.Charger and power supply cord	✘		
5.Screw,timing bar,swerving sets		✘▲	✘▲
6.Brake gasket		▲	▲
7.Rim		▲	▲
8.Frame,front fork		▲	▲
9.Bell,rear reflector		▲	▲
10.Chain		●	●
11.Pedals		✘●	✘●
12.Spokes		✘▲	✘▲

Content of free service under mentioned 3 provisions

NO.	Part	Free period	Problem description
-----	------	-------------	---------------------

1	Motor	2years	Motor cover ruptured,winding burnt
2	Controller	1year	Irreparable function problem
3	Charger	1year	Irreparable function problem
4	Battery(12Ah)	1year	Free change within 6months:Leak liquid,safe value out of control,Cover broken,capacity less than 60%, Free repair for 7-12months(calculate from produced date)
5	Battery(17-24Ah)	6months	Free change within 3months:Leak,safe value out of control,Cover broken,capacity less than 60%. free repair for 4-6months(calculate from produced date)
6	Frame,front fork rear fork	1year	Weld rupture,cracked,split.
7	Timing bar,brake clutch,meter,DC,convect or	6months	Irreparable function problem,exclude bent,appearance cracking.
8	Flasher,horn	1month	Irreparable function problem
9	Rear absorber, rear rack,saddle	1month	Rupture,distortion
10	Inner air tube	15days	Air leak,sand hole, Exclude repaired or incorrect riding.

※ Note:All free service for problems caused naturally only,excludes artificial operations.